11 - Broadband Amplifiers

The information in this work has been obtained from sources believed to be reliable. The author does not guarantee the accuracy or completeness of any information presented herein, and shall not be responsible for any errors, omissions or damages as a result of the use of this information.

August 2007

© 2006 by Fabian Kung Wai Lee

1

References

- [1]* G. Gonzalez, "Microwave transistor amplifiers - analysis and design", 2nd Edition 1997, Prentice-Hall.
- [2] D. M. Pozar, "Microwave engineering", 2nd Edition, 1998 John-Wiley & Sons.
- [3] G. D. Vendelin, A. M. Pavio, U. L. Rohde, "Microwave circuit design - using linear and nonlinear techniques", 1990, John-Wiley & Sons.

August 2007

© 2006 by Fabian Kung Wai Lee

2

Introduction

- Up to now we have been looking at amplifier design at one frequency or over a narrow band of frequencies centered at f_c (the carrier frequency). Narrow band in this context implies 5% of f_c or smaller.
- Here we will review broadband amplifier design.
- Some issues related to broadband amplifier design:
 - S-parameters of a transistor are dependent on frequency. Typically S_{21} decreases at a rate of 20dB/decade as frequency increase and S_{12} increases at the same rate with frequency.
 - S_{11} and S_{22} are also frequency dependent, this affect input and output matching.
 - There is a degradation of noise figure and VSWR in some frequency range of the amplifier.

Typical Methods of Achieving Broadband Operation

- Basically the design of a constant-gain amplifier over a broad frequency range is a matter of properly designing the matching networks, or feedback network to compensate for the variation of S-parameters with frequency.
- (1) The use of compensated impedance matching networks.
- (2) The use of negative feedback.
- (3) Combining either (1) or (2) with the balanced design approach.

1.0 Compensated Impedance Matching

Compensated Impedance Matching (1)

- A strategy of designing wideband amplifier using compensated impedance matching approach is to examine the expression for the transducer power gain.

$$G_T = \frac{(1 - |\Gamma_L|^2) |S_{21}|^2 (1 - |\Gamma_s|^2)}{|1 - S_{22}\Gamma_L|^2 |1 - \Gamma_1\Gamma_s|^2} \quad (1.1)$$

- If we enforce $\Gamma_s = 0$ (i.e. make $Z_s = Z_0$), then

$$G_{TL} = \frac{(1 - |\Gamma_L|^2) |S_{21}|^2}{|1 - S_{22}\Gamma_L|^2} \quad (1.2)$$

- A wideband impedance transformation network can then be designed to transform the load impedance Z_L so that Γ_L fulfills (1.2) within the operating frequency band.

Compensated Impedance Matching (2)

- For a fixed G_T , the values of Γ_L which fulfills (1.2) is a circle on the Smith chart. First we write (1.2) as:

$$\frac{G_{TL}(1-|S_{22}|^2)}{|S_{21}|^2} = g_L = \frac{(1-|\Gamma_L|^2)(1-|S_{22}|^2)}{|1-S_{22}\Gamma_L|^2}$$

- Following the procedures as outlined in Chapter 11, Pozar [2], this can be expanded as:

$$|\Gamma_s - T_{G_{TL}}|^2 = R_{G_{TL}}^2 \quad (1.3a)$$

$$T_{G_{TL}} = \frac{g_L \operatorname{Re}(S_{22}^*)}{1-(1-g_L)|S_{22}|^2} + j \frac{g_L \operatorname{Im}(S_{22}^*)}{1-(1-g_L)|S_{22}|^2} \quad (1.3b)$$

$$R_{G_{TL}} = \frac{\sqrt{1-g_L}(1-|S_{22}|^2)}{1-(1-g_L)|S_{22}|^2} \quad (1.3c)$$

Compensated Impedance Matching (3)

- A few constant constant G_{TL} circles will be plotted on the Smith chart for Γ_L at different frequencies.
- From these circles, suitable values of Z_L' will be identified at each frequency and a wideband impedance transformation network is designed to transform the actual load impedance Z_L to Z_L' at the designated frequency.
- Usually computer optimization method is needed for this procedure.
- An example will serve to illustrate this concept.

Example 1 - Wideband Amplifier Design with ADS Software Using Compensated Impedance Matching Method

- In this exercise, an attempt is made to design a wideband amplifier using compensated impedance transformation technique. The active device used is Phillips' BFR92A bipolar junction transistor.
- The intention is to design an amplifier with a transducer gain $G_T = 30$ (14.77dB) under the condition shown, with a bandwidth from 350MHz to 450MHz.

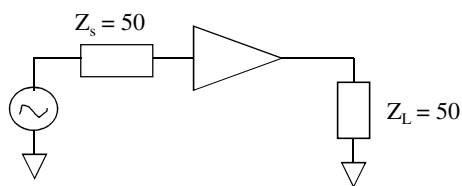

August 2007

© 2006 by Fabian Kung Wai Lee

9

Example 1 Cont...

- As a start the following CE amplifier is constructed. DC analysis and S-parameter analysis are performed.

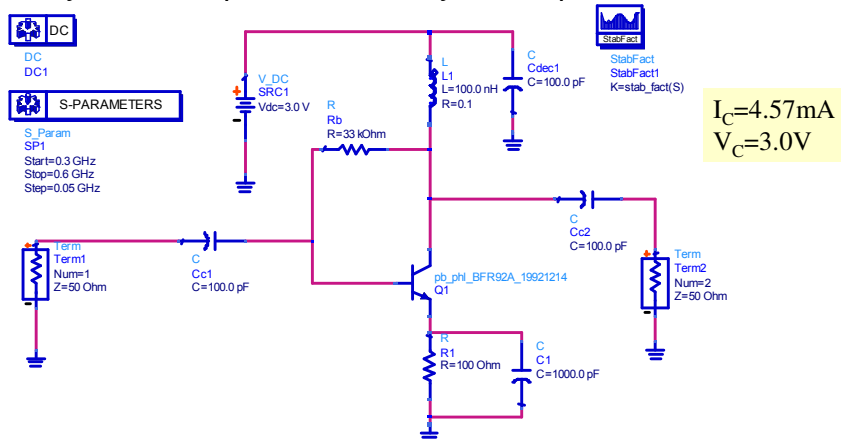

August 2007

© 2006 by Fabian Kung Wai Lee

10

Example 1 Cont...

- From the magnitude of S_{21} , it is evident that this circuit can provide G_T in excess of 30 when $\Gamma_s = \Gamma_L = 0$ ($Z_L = Z_s = Z_o = 50$).

freq	S(1,1)	S(2,1)	S(1,2)	S(2,2)	K
300.0MHz	0.588 / -73.754	9.147 / 136.949	0.057 / 74.493	0.618 / 3.223	0.572
350.0MHz	0.526 / -80.718	8.200 / 128.933	0.063 / 72.276	0.579 / -1.616	0.654
400.0MHz	0.475 / -86.913	7.406 / 122.439	0.067 / 70.975	0.547 / -4.954	0.724
450.0MHz	0.432 / -92.545	6.739 / 117.022	0.072 / 70.246	0.522 / -7.340	0.784
500.0MHz	0.396 / -97.756	6.174 / 112.393	0.077 / 69.877	0.502 / -9.105	0.835
550.0MHz	0.366 / -102.652	5.693 / 108.360	0.082 / 69.730	0.485 / -10.458	0.878
600.0MHz	0.340 / -107.305	5.280 / 104.785	0.087 / 69.716	0.471 / -11.533	0.914

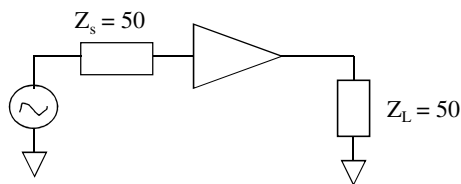

$$G_T = \frac{(1 - |\Gamma_L|^2) |S_{21}|^2 (1 - |\Gamma_s|^2)}{|1 - S_{22}\Gamma_L|^2 |1 - \Gamma_1\Gamma_s|^2}$$

$$\Gamma_s = 0 \quad \Gamma_L = 0$$

$$G_T = |S_{21}|^2$$

August 2007

© 2006 by Fabian Kung Wai Lee

11

Example 1 Cont...

- A plot of G_T versus frequency is shown below. Note that the transducer power gain varies greatly from around 65 to 45 over the intended operating frequency range.

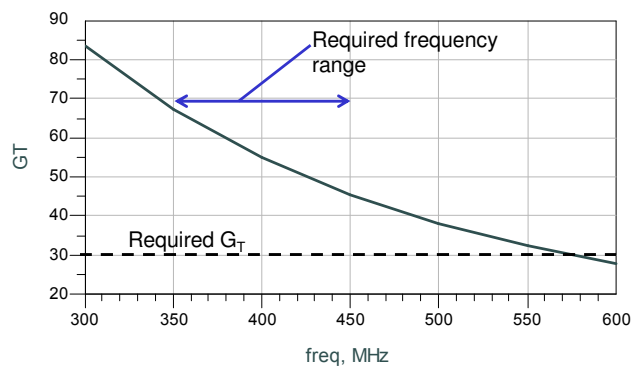

August 2007

© 2006 by Fabian Kung Wai Lee

12

Example 1 Cont...

- Equations (1.3b) & (1.3c) are used to find the center and radius corresponds to constant G_T circle ($G_T = 30$). The macros below are used in the ADS's data display for this purpose.

```
Eqn GTL=30      Eqn Zo=50
Eqn gL=(GTL*(1-pow(mag(S(2,2)),2)))/pow(mag(S(2,1)),2)
Eqn TGTL=gL*conj(S(2,2))/(1-(1-gL)*pow(mag(S(2,2)),2))
Eqn RGTL=(sqrt(1-gL)*(1-pow(mag(S(2,2)),2)))/(1-(1-gL)*pow(mag(S(2,2)),2))

Eqn theta=generate(0,2*pi,201)
Eqn Circle_GTL0=RGTL[1]*exp(j*theta)+TGTL[1]
Eqn Circle_GTL1=RGTL[2]*exp(j*theta)+TGTL[2]
Eqn Circle_GTL2=RGTL[3]*exp(j*theta)+TGTL[3]
```

← Circle for 350MHz
← Circle for 400MHz
← Circle for 450MHz

August 2007

© 2006 by Fabian Kung Wai Lee

13

Example 1 Cont...

- 3 constant G_{TL} circles are plotted, for $f = 350\text{MHz}$, 400MHz and 450MHz . 3 convenient points as shown are chosen for the required Γ_L .

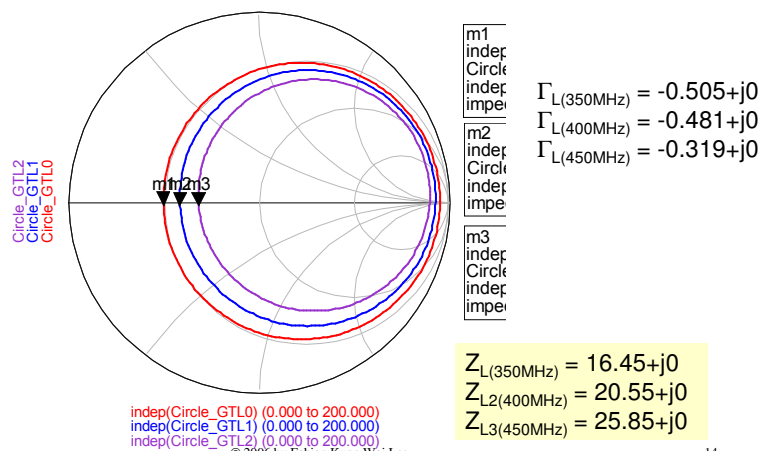

August 2007

© 2006 by Fabian Kung Wai Lee

14

Example 1 Cont...

- A pi network network is then proposed as the impedance transformation network that would give the required Z_L at $f = 350\text{MHz}$, 400MHz , and 450MHz .
- NOTE: A pi network is proposed as we have 3 variables in the pi network (C_1 , C_2 and L_1) and 3 degrees of freedom. This bodes well with 3 constraints as determined by the real values of Z_L at 350MHz , 400MHz and 450MHz .
- Optimization is carried out to find the best values for C_1 , C_2 and L_1 that will do the job. The optimization control with the associated goal functions are shown in the next slide.

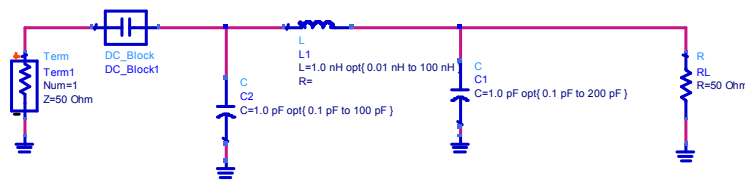

August 2007

© 2006 by Fabian Kung Wai Lee

15

Example 1 Cont...

S-PARAMETERS

S_Param
SP1
Start=0.35 GHz
Stop=0.45 GHz
Step=0.05 GHz

OPTIM

Optim
Optim1
OptimType=Gradient
ErrorForm=L2
MaxIters=200
DesiredError=0.0
StatusLevel=4
FinalAnalysis=None
SetBestValues=yes
Seed=
SaveSols=no
SaveGoals=yes
SaveOptimVars=no
UpdateDataset=yes
SaveNominal=yes
SaveAllIterations=no
UseAllOptVars=yes

GOAL

Goal
OptimGoal1
Expr="mag(real(S11)-(-0.505))"
SimInstanceName="SP1"
Min=
Max=0.02
Weight=
RangeVar[1]="freq"
RangeMin[1]=350MHz
RangeMax[1]=350MHz

GOAL

Goal
OptimGoal2
Expr="mag(real(S11)-(-0.418))"
SimInstanceName="SP1"
Min=
Max=0.02
Weight=
RangeVar[1]="freq"
RangeMin[1]=400MHz
RangeMax[1]=400MHz

GOAL

Goal
OptimGoal3
Expr="mag(real(S11)-(-0.319))"
SimInstanceName="SP1"
Min=
Max=0.02
Weight=
RangeVar[1]="freq"
RangeMin[1]=450MHz
RangeMax[1]=450MHz

GOAL

Goal
OptimGoal4
Expr="pow(imag(S11),2)"
SimInstanceName="SP1"
Min=
Max=0.02
Weight=
RangeVar[1]="freq"
RangeMin[1]=350MHz
RangeMax[1]=450MHz

August 2007

© 2006 by Fabian Kung Wai Lee

16

Example 1 Cont...

- The transformed load impedance using the pi network.

The optimized results, after 12 iterations

NumIters	InitialEF	FinalEF	C1.C	C2.C	L1.L
12.000	0.450	0.000	1.270E-11	1.087E-11	1.249E-8

freq	S(1,1)	Z(1,1)
300.0MHz	0.507 / -159.704	16.842 - j7.962
350.0MHz	0.492 / -171.119	17.123 - j3.430
400.0MHz	0.438 / 175.056	19.569 + j1.828
450.0MHz	0.330 / 155.187	26.082 + j8.109
500.0MHz	0.163 / 110.351	42.688 + j13.418

Compare these with the requirements

August 2007

© 2006 by Fabian Kung Wai Lee

17

Example 1 Cont...

- Finally, the pi network is incorporated into the original circuit, and an S-parameter analysis is performed to verify the performance of the complete circuit.

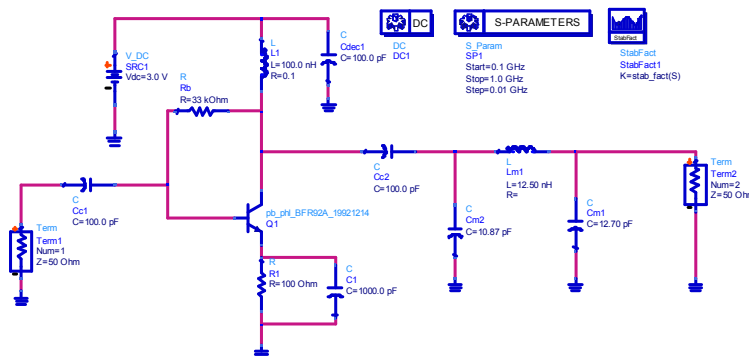

August 2007

© 2006 by Fabian Kung Wai Lee

18

Example 1 Cont...

$$\text{Eqn } GT_{wb} = \text{pow}(\text{mag}(S(2,1)), 2)$$

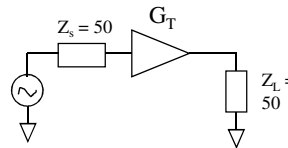
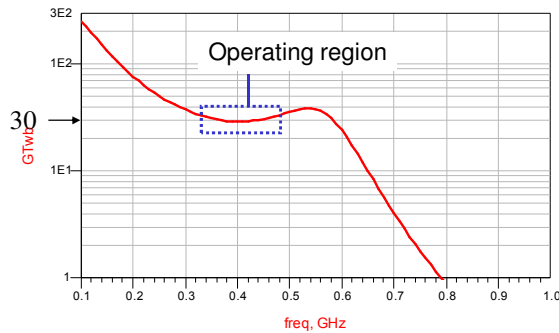
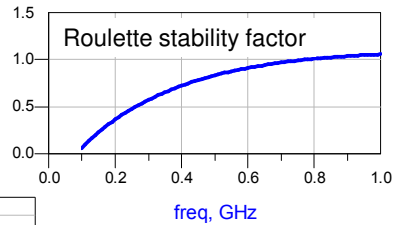

August 2007

© 2006 by Fabian Kung Wai Lee

19

Drawbacks of this Approach

- Usually is limited to bandwidth of 1 decade.
- Considerable ripple is present within the operating bandwidth.
- The design of the required impedance transformation network is more of an art, largely a hit or miss affair.
- Power gain is not optimized, as seen in this example, there is large amount of mismatch at the input and output. Power gain is sacrificed at the expense of wideband operation.

August 2007

© 2006 by Fabian Kung Wai Lee

20

2.0 Negative Feedback

Negative Feedback

- Negative feedback is widely used in amplifier design for the following reasons:
 - Negative feedback stabilizes the gain of the amplifier against parameter changes in the active device due to voltage variation, temperature drift or device aging.
 - To increase the bandwidth of the amplifier (at the expense of maximum gain).
 - To improve the gain linearity of an amplifier.
 - To change the input and output impedance of the amplifier.
- For a detailed discussion on negative feedback, please refer to chapter 8 of Gray & Meyer [2].



Negative Feedback Review (1)

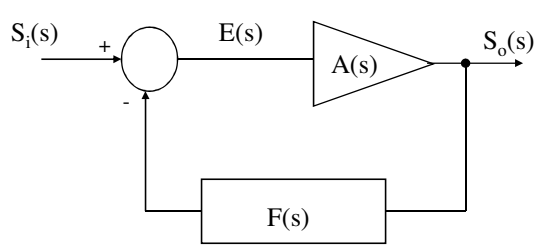

$$\frac{S_o(s)}{S_i(s)} = G(s) = \frac{A(s)}{1 + A(s)F(s)}$$

Closed-loop gain (2.1)

$$T(s) = A(s)F(s)$$

Loop gain (2.2)

Properties of G(s):

$$\frac{\Delta G(s)}{G(s)} = \frac{\Delta A(s)}{A(s)} \frac{1}{1 + T(s)}$$

Stabilization of gain against parameter variation

If $T(s) \gg 1$ \Rightarrow $\frac{S_o(s)}{S_i(s)} \cong \frac{1}{F(s)}$



Negative Feedback Review (2)

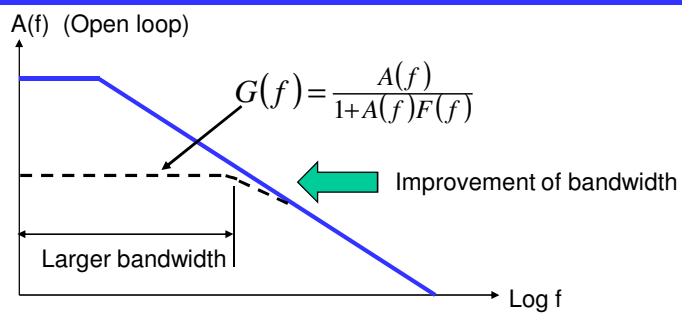

- 4 basic configurations of feedback system:
 - Shunt-shunt feedback.
 - Shunt-series feedback.
 - Series-shunt feedback.
 - Series-series feedback.

Implementing Local Negative Feedback on Transistor and FET

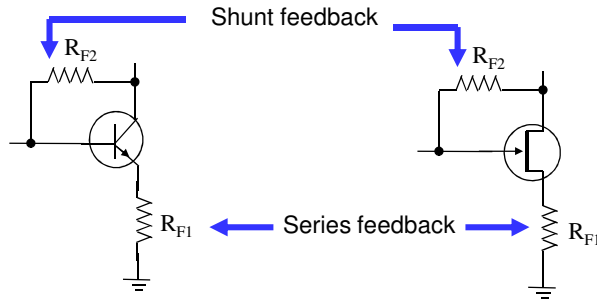

The shunt and series feedback can be implemented separately or together.

More on Local Feedbacks on Transistor and FET

Only shunt feedback:

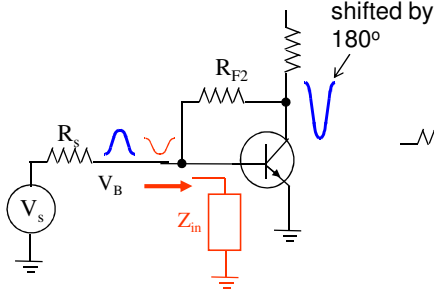

For detailed analysis see Chapter 8, Gray & Meyer [2]

Only series feedback:

$$I_C + i_c = I_{se} e^{\left[\frac{(V_B + v_b) - (V_E + v_e)}{V_T} \right]}$$

$$I_C + i_c = I_{se} e^{\left[\frac{(V_B - V_E) + (v_b - v_e)}{V_T} \right]}$$

$$I_C + i_c \cong I_{se} e^{\left[\frac{(V_B - V_E)}{V_T} \right]} e^{\left[\frac{(v_b - v_e)}{V_T} \right]}$$

$$\Rightarrow i_c \cong \left(\frac{I_C}{V_T} \right) (v_b - v_e)$$

$$\Rightarrow i_c \cong \left(\frac{I_C}{V_T} \right) (v_b - i_c R_{F1})$$

Note that $I_C \cong I_{se} e^{\frac{V_B - V_E}{V_T}}$

Using Y and Z Parameters with Feedback (1)

Extra

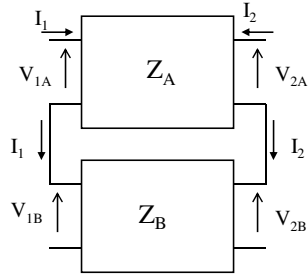

$$\begin{bmatrix} V_1 \\ V_2 \end{bmatrix} = \begin{bmatrix} V_{1A} \\ V_{2A} \end{bmatrix} + \begin{bmatrix} V_{1B} \\ V_{2B} \end{bmatrix} = (\bar{\bar{Z}}_A + \bar{\bar{Z}}_B) \begin{bmatrix} I_1 \\ I_2 \end{bmatrix}$$

(2.3a)

Series Feedback

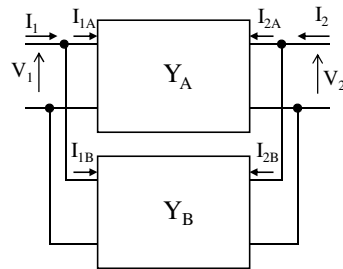

$$\begin{bmatrix} I_1 \\ I_2 \end{bmatrix} = \begin{bmatrix} I_{1A} \\ I_{2A} \end{bmatrix} + \begin{bmatrix} I_{1B} \\ I_{2B} \end{bmatrix} = (\bar{\bar{Y}}_A + \bar{\bar{Y}}_B) \begin{bmatrix} V_1 \\ V_2 \end{bmatrix}$$

(2.3b)

Shunt Feedback

August 2007

© 2006 by Fabian Kung Wai Lee

27

Using Y and Z Parameters with Feedback (2)

Extra

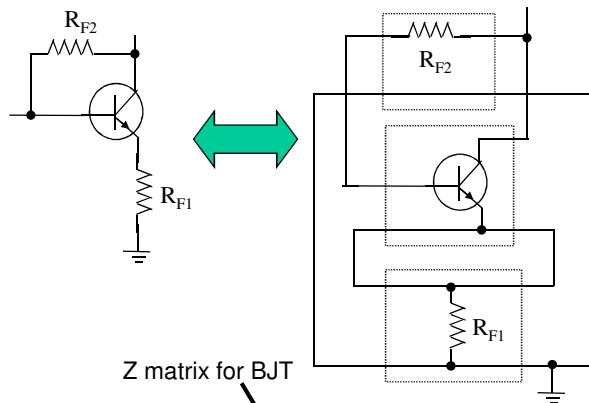

Z matrix for BJT

$$\bar{\bar{Y}} = \begin{bmatrix} \frac{1}{R_{F2}} & \frac{-1}{R_{F2}} \\ \frac{-1}{R_{F2}} & \frac{1}{R_{F2}} \end{bmatrix} \quad (2.4a)$$

$$\bar{\bar{Z}} = \begin{bmatrix} R_{F1} & R_{F1} \\ R_{F1} & R_{F1} \end{bmatrix} \quad (2.4b)$$

$$\begin{aligned} S_{11t} &= \frac{(Y_o - y_{11})(Y_o + y_{22}) + y_{12}y_{21}}{\Delta y} \\ S_{12t} &= \frac{-2y_{12}Y_o}{\Delta y} \\ S_{21t} &= \frac{-2y_{21}Y_o}{\Delta y} \\ S_{22t} &= \frac{(Y_o + y_{11})(Y_o - y_{22}) + y_{12}y_{21}}{\Delta y} \\ \Delta y &= (Y_o + y_{11})(Y_o + y_{22}) - y_{12}y_{21} \end{aligned} \quad (2.4c)$$

$$\bar{\bar{Y}}_t = \left\{ \begin{bmatrix} R_{F1} & R_{F1} \\ R_{F1} & R_{F1} \end{bmatrix} + \begin{bmatrix} z_{11} & z_{12} \\ z_{21} & z_{22} \end{bmatrix} \right\}^{-1} + \begin{bmatrix} \frac{1}{R_{F2}} & \frac{-1}{R_{F2}} \\ \frac{-1}{R_{F2}} & \frac{1}{R_{F2}} \end{bmatrix}$$

Using Y to S matrix transformation $\bar{\bar{S}}_{total}$

August 2007

© 2006 by Fabian Kung Wai Lee

28

Simplified Low-Frequency Feedback Analysis (1)

Extra

- The following derivation is taken from Chapter 4 of Gonzalez [1]. Consider a low frequency FET model with feedback:

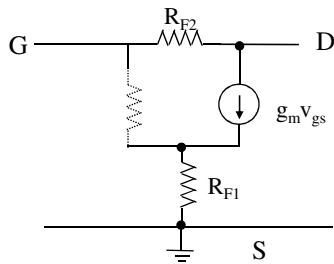

This is also applicable to BJT provided:

$$r_{b'e} + h_{fe} R_{F1} \gg R_{F2} \quad (2.7)$$

The Y_t matrix can be easily derived:

$$Y_t = \begin{bmatrix} \frac{1}{R_{F2}} & \frac{-1}{R_{F2}} \\ \frac{g_m}{1+g_m R_{F1}} + \frac{-1}{R_{F2}} & \frac{1}{R_{F2}} \end{bmatrix} \quad (2.5)$$

And converted to S-parameter:

$$\begin{aligned} S_{11t} = S_{22t} &= \frac{1}{D} \left[1 - \frac{g_m Z_o^2}{R_{F2}(1+g_m R_{F1})} \right] \\ S_{21t} &= \frac{1}{D} \left(\frac{-2g_m Z_o}{1+g_m R_{F1}} + \frac{2Z_o}{R_{F2}} \right) \\ S_{12t} &= \frac{2Z_o}{DR_{F2}} \\ D &= 1 + \frac{2Z_o}{R_{F2}} + \frac{g_m Z_o^2}{R_{F2}(1+g_m R_{F1})} \end{aligned} \quad (2.6)$$

August 2007

© 2006 by Fabian Kung Wai Lee

29

Simplified Low-Frequency Feedback Analysis (2)

Extra

- If we require that:

$$1 + g_m R_{F1} = \frac{g_m Z_o^2}{R_{F2}} \quad \Rightarrow \quad R_{F1} = \frac{Z_o^2}{R_{F2}} - \frac{1}{g_m} \quad (2.8)$$

- Then $S_{11t} = S_{22t} = 0$ (2.9a)

$$S_{21t} = \frac{Z_o - R_{F2}}{Z_o} \quad (2.9b)$$

$$S_{12t} = \frac{Z_o}{Z_o + R_{F2}} \quad (2.9c)$$

- In the case when only shunt feedback is applied ($R_{F1} = 0$):

$$\frac{1}{g_m} = \frac{Z_o^2}{R_{F2}} \quad (2.10a)$$

$$R_{F2} = Z_o(1 - S_{21}) \quad (2.10b)$$

For BJT additional requirement:

$$r_{b'e} \gg R_{F2}$$

Observe that S-parameters is no longer dependent on active device parameter

August 2007

© 2006 by Fabian Kung Wai Lee

30

Typical Local Negative Feedbacks on Transistor and FET at RF

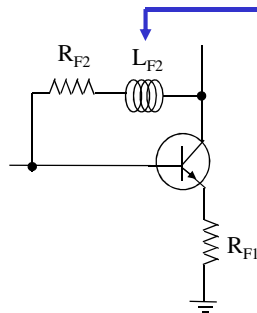

- At high frequency, phase difference between voltage at collector and base will be less than 180°. Instead of negative feedback, this could lead to positive feedback, resulting in instability. L_{F2} is used to introduce 90° phase lead when the phase difference between C and B is less than 90°.
- The phase difference information can be obtained from S_{21} .

August 2007

© 2006 by Fabian Kung Wai Lee

31

Design Equations for Negative Feedback Amplifier

- In general to implement local feedback on BJT or FET, we begin with the low frequency design.
- Equations (2.8) and (2.9b) are used to find the approximate values for R_{F1} and R_{F2} .

$$R_{F1} = \frac{Z_o^2}{R_{F2}} - \frac{1}{g_m} \quad S_{21t} = \frac{Z_o - R_{F2}}{Z_o}$$

- In the low frequency model S_{21} is negative (e.g. 180° phase shift), hence (2.9b) can be written as:

$$R_{F2} = Z_o(1 + |S_{21t}|) \quad (2.11)$$

- Since at high frequency parasitic capacitance and inductance effect become evident, CAD software is then used to fine tune the resistor values to obtain good input/output VSWR (i.e. S_{11t} and S_{22t} close to 0) and fairly constant S_{21t} and S_{12t} as a function of frequency.

$$\omega_1 L_{F2} = R_{F2} \quad (2.12)$$

ω_1 = frequency where S_{21} of active device phase is less than 90°

August 2007

© 2006 by Fabian Kung Wai Lee

32

Example 2 - Negative Feedback Amplifier Design Example with ADS Software

- In this exercise, an attempt is made to design a wideband amplifier using negative feedback technique. The active device used is BFR92A bipolar junction transistor.
- The objectives:
 - To stabilize $|S_{21t}|$ to around 3.2 between 100MHz-1000MHz.
 - S_{11t} and S_{22t} close to zero within the same frequency range.

August 2007

© 2006 by Fabian Kung Wai Lee

33

Example 2 Cont...

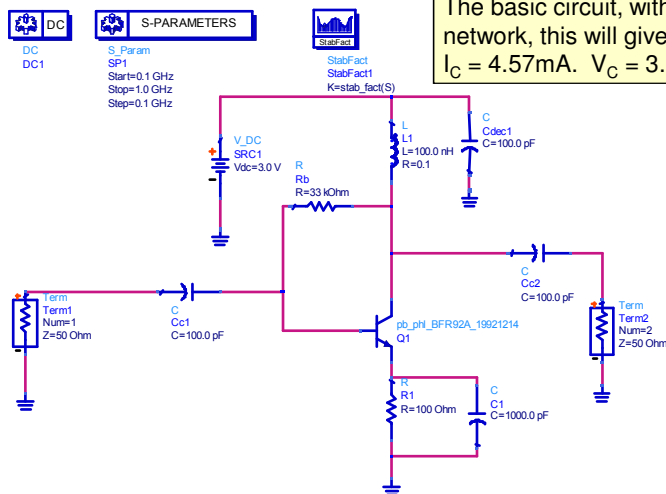

August 2007

© 2006 by Fabian Kung Wai Lee

34

Example 2 Cont...

- The S-parameters for the basic circuit:

freq	S(1,1)	S(2,1)	S(1,2)	S(2,2)	K
100.0MHz	0.953 / -30.336	13.323 / -145.899	0.026 / 115.045	0.885 / 79.968	0.061
200.0MHz	0.753 / -56.236	11.532 / 161.011	0.045 / 84.359	0.729 / 22.013	0.364
300.0MHz	0.588 / -73.754	9.147 / 136.949	0.057 / 74.493	0.618 / 3.223	0.572
400.0MHz	0.475 / -86.913	7.406 / 122.439	0.067 / 70.975	0.547 / -4.954	0.724
500.0MHz	0.396 / -97.756	6.174 / 112.393	0.077 / 69.877	0.502 / -9.105	0.835
600.0MHz	0.340 / -107.305	5.280 / 104.785	0.087 / 69.716	0.471 / -11.533	0.914
700.0MHz	0.300 / -116.087	4.609 / 98.647	0.097 / 69.880	0.449 / -13.181	0.971
800.0MHz	0.270 / -124.378	4.092 / 93.464	0.108 / 70.105	0.432 / -14.467	1.011
900.0MHz	0.247 / -132.318	3.683 / 88.937	0.119 / 70.282	0.418 / -15.589	1.040
1.000GHz	0.231 / -139.963	3.353 / 84.881	0.130 / 70.365	0.407 / -16.647	1.059

S_{21} has magnitude > 3.2
from 100MHz to 1000MHz.
Also note that the phase
is less than 90° beginning
from 700MHz. So we choose
 $S_{21(\text{feedback})} = 3.2$

Note a small K stability factor indicates
the basic amplifier is less stable at the
low frequency range.

August 2007

© 2006 by Fabian Kung Wai Lee

35

Example 2 Cont...

- Finding the low frequency approximation values for R_{F1} , R_{F2} and approximation for L_{F2} .

$$R_{F2} = Z_o (1 + |S_{21t}|) = 50(1 + 3.2) = 210\Omega$$

$$g_m = \left(\frac{I_C}{q} \right) \approx \frac{0.00457}{0.026} = 0.1758$$

$$R_{F1} = \frac{Z_o^2}{R_{F2}} - \frac{1}{g_m} = 6.22\Omega$$

$$L_{F2} = \frac{R_{F2}}{2\pi f_1} = 47.75nH$$

$$f_1 = 700MHz$$

August 2007

© 2006 by Fabian Kung Wai Lee

36

Example 2 Cont...

Feedback network is added. Tuning is carried to optimize the S-parameters of the resulting amplifier.

Noise analysis is enabled

The final values:
 $R_{F1} = 270 \text{ Ohm}$
 $R_{F2} = 2.2 \text{ Ohm}$
 $L_{F2} = 33.0 \text{ nH}$
 A capacitor C_{F1} is added in series to act as d.c. block.

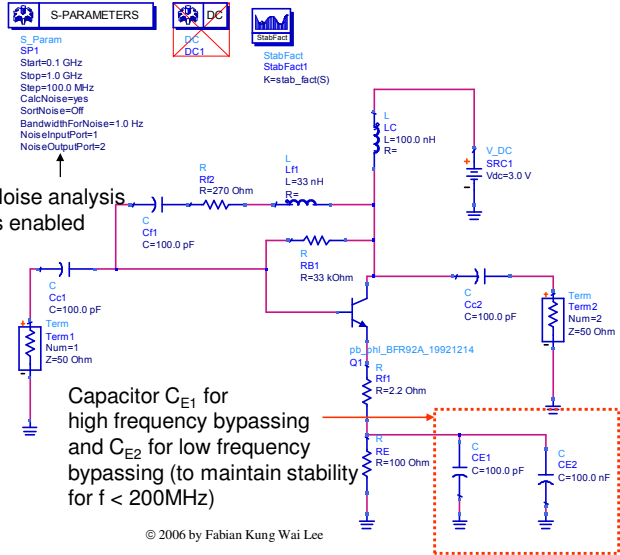

August 2007

© 2006 by Fabian Kung Wai Lee

37

Example 2 Cont...

- The S-parameters for the amplifier with shunt and series feedback:

freq	S(2,1)	S(1,1)	S(2,2)	S(1,2)	K	mag(D)
100.0MHz	4.109 / -148.950	0.337 / -91.905	0.411 / 155.262	0.131 / 44.510	1.089	0.674
200.0MHz	4.311 / -177.298	0.162 / -118.464	0.329 / 117.327	0.139 / 24.522	1.072	0.645
300.0MHz	4.291 / 167.529	0.099 / -137.625	0.351 / 96.728	0.139 / 18.717	1.048	0.623
400.0MHz	4.213 / 155.688	0.066 / -152.510	0.391 / 81.187	0.139 / 16.460	1.025	0.597
500.0MHz	4.095 / 145.287	0.045 / -161.319	0.432 / 68.233	0.137 / 15.802	1.010	0.566
600.0MHz	3.943 / 135.786	0.032 / -160.105	0.467 / 56.973	0.134 / 16.295	1.008	0.532
700.0MHz	3.767 / 127.023	0.028 / -148.253	0.492 / 47.017	0.130 / 17.387	1.022	0.497
800.0MHz	3.575 / 118.951	0.032 / -137.738	0.508 / 38.172	0.127 / 20.582	1.050	0.463
900.0MHz	3.378 / 111.549	0.041 / -135.833	0.516 / 30.314	0.125 / 24.287	1.087	0.433
1.000GHz	3.183 / 104.787	0.051 / -139.405	0.517 / 23.338	0.125 / 28.744	1.126	0.408

Good matching to $Z_0 = 50$ for input

Magnitude of S_{211} did not change much

Also note that because of feedback, the amplifier becomes unconditionally stable throughout the operating range.

August 2007

© 2006 by Fabian Kung Wai Lee

38

Example 2 Cont...

- Plotting the transducer gain G_T with $Z_s = Z_L = Z_o$. Also plotted are the noise figure at output.

Noise figure without feedback

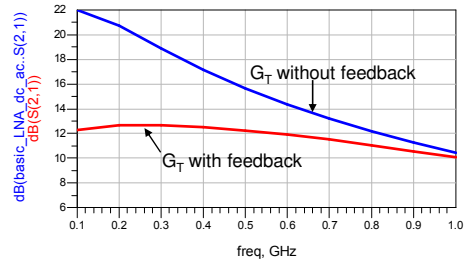
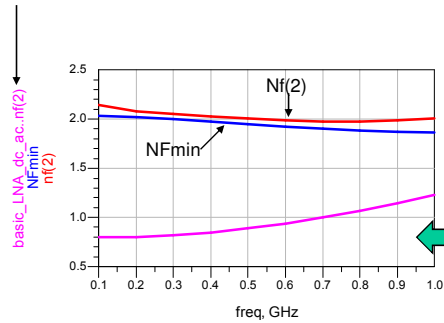

R_{F1} and R_{F2} degrade the noise performance slightly.

August 2007

© 2006 by Fabian Kung Wai Lee

39

3.0 Balance Amplifier

August 2007

© 2006 by Fabian Kung Wai Lee

40

Balanced Amplifier

- The first 90° 3dB coupler divides the input signal into two equal-amplitude components with a 90° phase difference.
- The second 90° 3dB coupler recombines the amplifier outputs.
- Because of the phasing properties of the coupler, reflections from the amplifier inputs cancel at the input to the coupler, resulting in improved impedance match.
- A similar condition occurs at the output.

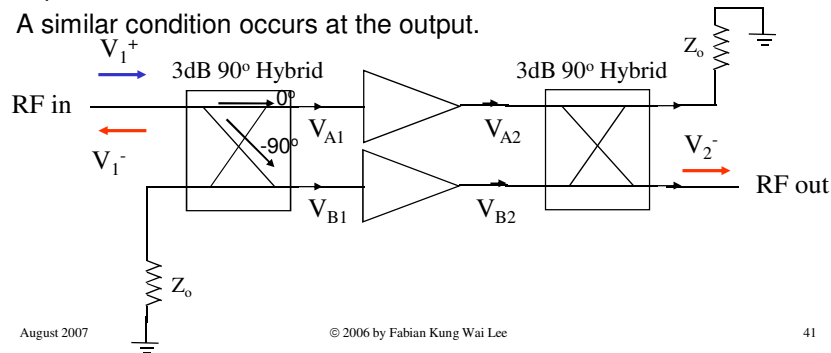

August 2007

© 2006 by Fabian Kung Wai Lee

41

Derivation of S-parameters for Balanced Amplifier (1)

Extra

- Assuming the 3dB hybrid couplers are ideal. Impedance looking into each port is equal to Z_0 . Then:

$$\begin{aligned}
 V_{A1}^+ &= \frac{1}{\sqrt{2}} V_1^+ & V_{B1}^+ &= \frac{-j}{\sqrt{2}} V_1^+ \\
 V_2^- &= \frac{-j}{\sqrt{2}} V_{A2}^+ + \frac{1}{\sqrt{2}} V_{B2}^+ = \frac{-j}{\sqrt{2}} S_{21A} V_{A1}^+ + \frac{1}{\sqrt{2}} S_{21B} V_{B1}^+ \\
 &= \frac{-j}{\sqrt{2}} S_{21A} \frac{1}{\sqrt{2}} V_1^+ + \frac{1}{\sqrt{2}} S_{21B} \frac{-j}{\sqrt{2}} V_1^+ = \frac{-j}{2} V_1^+ (S_{21A} + S_{21B}) \\
 S_{21\text{Balanced}} &= \frac{V_2^-}{V_1^+} = \frac{-j}{2} (S_{21A} + S_{21B}) \quad (3.1a)
 \end{aligned}$$

- In a similar manner:

$$\begin{aligned}
 V_1^- &= \frac{1}{\sqrt{2}} V_{A1}^- + \frac{-j}{\sqrt{2}} V_{B1}^- = \frac{1}{\sqrt{2}} S_{11A} V_{A1}^+ + \frac{-j}{\sqrt{2}} S_{11B} V_{B1}^+ \\
 &= \frac{1}{2} V_1^+ (S_{11A} - S_{11B}) \\
 S_{11\text{Balanced}} &= \frac{V_1^-}{V_1^+} = \frac{1}{2} (S_{11A} - S_{11B}) \quad (3.1b)
 \end{aligned}$$

August 2007

© 2006 by Fabian Kung Wai Lee

42



Derivation of S-parameters for Balanced Amplifier (2)

- If both amplifiers are equal:

$$S_{21A} = S_{21B} = S_{21} \quad S_{11A} = S_{11B} = S_{11} \quad S_{12A} = S_{12B} = S_{12} \quad S_{22A} = S_{22B} = S_{22}$$

- And

$$S_{21\text{Balanced}} = -jS_{21} \quad S_{11\text{Balanced}} = 0$$

- Finally, using similar approach, it can also be shown that:

$$S_{12\text{Balanced}} = -jS_{12} \quad S_{22\text{Balanced}} = 0 \quad (3.2)$$

$$\underline{\underline{S}}_{\text{Balanced}} = \begin{bmatrix} 0 & -jS_{12} \\ -jS_{21} & 0 \end{bmatrix}$$

Advantages of Balanced Amplifier

- The balanced amplifier has the following interesting advantages.
- The individual amplifier stages can be optimized for gain flatness or noise figure, without concern for input and output matching.
- Reflections are absorbed in the coupler terminations, improving input/output matching as well as stability of the individual amplifiers.
- Bandwidth greater than a decade or more can be achieved, primarily limited by the bandwidth of the coupler.
- The essence of wideband balanced amplifier – **Each amplifier itself must be wideband.**